

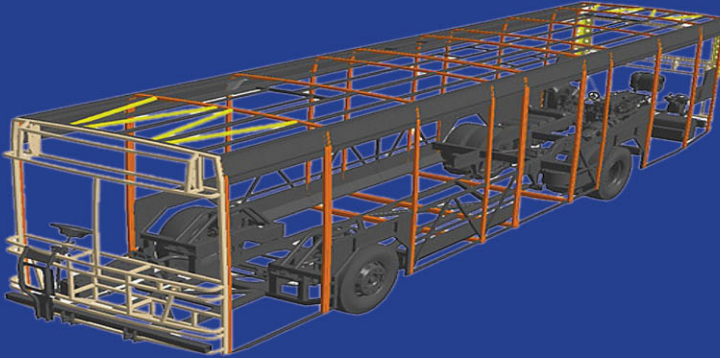

नेपाल सरकार
भौतिक पूर्वाधार तथा यातायात मन्त्रालय
यातायात व्यवस्था विभाग

बस बडी बिल्डिंग मापदण्ड, २०७४ (Bus Body Building Standard, 2018)



काठमाडौं
२०७४



नेपाल सरकार
भौतिक पूर्वाधार तथा यातायात मन्त्रालय
यातायात व्यवस्था विभाग

बस बडी बिल्डिंग मापदण्ड, २०७४
(Bus Body Building Standard, 2018)

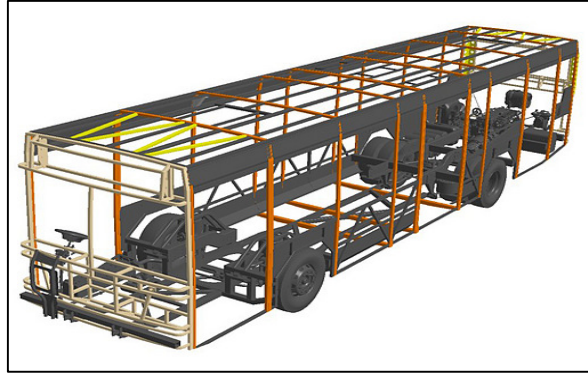

काठमाडौं
२०७४

बस बडी बिल्डिंग मापदण्ड, २०७४

स्वीकृत मिति: २०७४/१२/१६

सवारी तथा यातायात व्यवस्था ऐन, २०४९ दफा १५९ मा व्यवस्था भए बमोजिम प्रशिक्षण केन्द्र, कारखाना तथा वर्कशप दर्ता तथा संचालन सम्बन्धी कानूनी प्रावधान कार्यान्वयन गर्न सवारी तथा यातायात व्यवस्था नियमावली, २०५४ को नियम ६२ ले दिएको अधिकार प्रयोग गरी सार्वजनिक यातायात सेवालाई सुरक्षित एवं भरपर्दो बनाउने उद्देश्यले भौतिक पूर्वाधार तथा यातायात मन्त्रालयको मिति २०७४/१२/७ गतेको सैद्धान्तिक सहमति अनुसार यातायात व्यवस्था विभागले **‘बस बडी बिल्डिंग मापदण्ड, २०७४’** जारी गरेको छ ।

१. यो निर्देशिका यातायात व्यवस्था विभागले स्वीकृत गरेको मितिबाट लागू हुनेछ ।
२. यो मापदण्ड “कारखाना तथा वर्कशप संचालन निर्देशिका, २०७४” बमोजिमको वर्कशप वर्ग (ड) को कार्यान्वयन गर्नका लागि तयार गरिएको छ ।

TABLE OF CONTENTS

1.	Scope of the Guidelines.....	7
2.	Definitions and Terminology	7
3.	Components of Bus Body Structure.....	11
4.	General Requirements of Bus Body Design.....	12
4.1	<i>Categories of Buses and Services</i>	12
4.2	<i>Overall Dimensions</i>	13
4.3	<i>Internal Dimensions</i>	13
a.	Service Doors.....	13
b.	Window	14
c.	Emergency Exits.....	14
d.	Steps	15
e.	Gangway	16
f.	Hand Rails Hand-Holds, Hand Straps.....	16
g.	Hand Rails and Hand Holds for Service Doors.....	17
h.	Guarding of Step-Wells	18
i.	Seats.....	18
j.	Cabin Luggage Rack:.....	19
4.4	<i>Destination Board for Public Service Vehicles</i>	19
4.5	<i>Driver’s Work Area</i>	20
4.6	<i>Standee Passenger Area</i>	21
4.7	<i>Provisions for Disabled Passengers</i>	22
5.	Technical and Safety Requirements	22
5.1	<i>Body Structure Strength</i>	22
5.2	<i>Body Structure Stability</i>	22
5.3	<i>Joint Strength</i>	22
5.4	<i>Service Doors</i>	22
5.5	<i>Emergency Doors</i>	23
5.6	<i>Emergency Windows</i>	24
5.7	<i>Escape Hatches</i>	24
5.8	<i>Marking of Emergency Exits:</i>	24
5.9	<i>Door Components</i>	24
5.10	<i>Windows</i>	24
5.11	<i>Ingress of Dust And Rain Water</i>	25
5.12	<i>Body Insulation</i>	25
5.13	<i>Rear View Mirrors</i>	25
5.14	<i>Wind Screen Wiping System and Driver’s Field of Visions</i>	25
5.15	<i>Vehicle Seats and Seat Belts</i>	25

5.16	<i>Strength Roof Luggage Carrier</i>	25
5.17	<i>Bumpers</i>	26
5.18	<i>Corrosion Protection</i>	26
5.19	<i>Protection against Fire Risk</i>	26
5.20	<i>Fuel Filler Apertures:</i>	26
5.21	<i>Fuel Tank:</i>	26
5.22	<i>Fuel Feed System</i>	26
5.23	<i>Fire Extinguishers</i>	27
5.24	<i>First Aid Equipment</i>	27
5.25	<i>Modification of Chassis And / or Chassis Related Components</i>	27
5.26	<i>Air Conditioning (AC) System</i>	27
6.	Lighting and Illumination	27
6.1	<i>Lighting, Signaling and Indicating Systems</i>	27
6.2	<i>Position of Illumination Devices</i>	28
6.3	<i>Type of Bulbs for Lamp Assemblies</i>	28
6.4	<i>Photometric requirements</i>	28
6.5	<i>Driver Cabin Lighting</i>	29
6.6	<i>Passenger Compartment Lighting</i>	29
6.7	<i>Other Area Lightings</i>	29
6.8	<i>Type Approval</i>	30
7.	Electrical Equipment and wiring	30
7.1	<i>Electrical Cables</i>	30
7.2	<i>Fuse</i>	30
7.3	<i>Terminals, Connectors & Elements</i>	30
7.4	<i>Safety Requirements</i>	30
7.5	<i>Batteries</i>	31
7.6	<i>Type Approval</i>	31
8.	Bus Body Test Methods	31
8.1	<i>Design of Bus Bodies</i>	31
8.2	<i>Body Structure Strength Test</i>	31
8.3	<i>Test Methods</i>	32
8.4	<i>Acceptance Criteria</i>	32
8.5	<i>Roll-Over Test on a Complete Vehicle</i>	32
a.	<i>Test Conditions</i>	32
b.	<i>Test Procedure</i>	33
8.6	<i>Stability Test</i>	34
a.	<i>Test Condition</i>	34
b.	<i>Test Method</i>	34
c.	<i>Acceptance Criteria</i>	34
8.7	<i>Joint Strength Test</i>	34

8.8	<i>Test Procedure</i>	35
9.	Type Approval and COP Procedure.....	35
9.1	<i>Scope</i>	35
9.2	<i>Procedure for Type Approval</i>	35
9.3	<i>Application for Type Approval</i>	36
9.4	<i>Type Approval of Safety Components / Sub-Assemblies</i>	37
9.5	<i>Methods of Establishing Compliance</i>	37
9.6	<i>Certificate of Compliance (Type-Approval)</i>	37
10.	Technical Specification Form	37

LIST OF FIGURES

Figure 1 Bus Body Components	11
Figure 2 Bus Type and Transport Service	13
Figure 3 Dimensional Requirements for Steps.....	16
Figure 4 Typical Hand Holds	17
Figure 5 Driver's Work Area Requirements	21
Figure 6 Residual Space After Lateral Intrusion	32
Figure 7 Sectional View At A-A	32
Figure 8 Test Setup for Rollover Test	33
Figure 9 Test Setup for Stability Test.....	34
Figure 10 Body Fabrication and Type Approval.....	36

LIST OF TABLES

Table 1 General Dimensions of Various Kinds of Buses.....	13
Table 2 Dimensions of Door	14
Table 3 Dimension Requirements for Steps.....	15
Table 4 The Minimum Width of the Passage (Gangway).....	16
Table 5 Width of Seat Cushion	18
Table 6 Backrest Height, mm.....	19
Table 7 Minimum Armrest, mm.....	19
Table 8 Minimum Dimensions of Cabin Luggage Rack.....	19
Table 9 Dimensions of Roof Access Ladder.....	19
Table 10 Size of the Destination Board.....	20
Table 11 Dimension Requirement for Drivers' Work Place.....	21
Table 12 Door Component Standards	24
Table 13 Type and the Minimum Number of Extinguishers.....	27
Table 14 Specification for Low Tension Wire for Automobile Application.....	30
Table 15 Technical Specification Form	37

1. SCOPE OF THE GUIDELINES

These guidelines are intended to be used for the approval procedure of the body fabrication. The guidelines will be helpful for technicians as well as engineers engaged in the design and construction of the bus body in a workshop. Further, these guidelines will be used as a tool for the monitoring and approval by DoTM officials. This document will be helpful for the harmonization and standardization of bus building industries in the country. It covers mainly the following aspects of the bus body design and guidelines.

- a. Categorization of buses based on the seating capacity and on minimum comfort levels and the type of operation,
- b. Requirements on the various safety related features like entry / exit door, emergency exits, window frames, their locations, dimensions and designs,
- c. Standardization of the floor level height, gangways and dimensions of the footsteps,
- d. Requirements on the dimension of seats, seating layout, lighting and illumination,
- e. Requirements for driver's workplace,
- f. Requirements for the persons with disabilities.
- g. Testing methods for stability and strength of the bus body structure, seat anchorages etc., including the roll over test for the full body.

The provisions of this guideline are applicable to buses with a seating capacity of 15 passengers or above including driver.

2. DEFINITIONS AND TERMINOLOGY

Bus Body	The portion of a bus that encloses the bus's occupant space, exclusive of the bumpers, the chassis frame any structure forward and of the forward most point of the windshield mounting
Ladder Type Chassis	The chassis frame of the vehicle and is the main load bearing element. The general construction of ladder frame consists of side and cross members. The side and cross members are connected with special gusset sections or pressed cross member sections The junctions are riveted, bolted or welded
Monocoque Construction	A type of bus body structure where the body and base frame are joined together either by welding or by other methods to form an integral structure. These structural elements consist of pressed grid type of support elements and rectangular sections
Type I (Bus)	<p>These types of vehicles are the high capacity vehicles designed and constructed for urban and sub urban / city transport with area for standing passengers, to allow movement of passengers associated with frequent stops.</p> <p>These buses serve for Local routes and Normal bus service standard. This type is designed for the day time operation only. Comfort level may vary as per requirement such as deluxe as well as AC deluxe.</p>

Type II (Bus)	<p>These type of vehicles are those, designed and constructed for inter-urban/inter-city transport without specified area for standing passengers, but can carry standing passengers over short distance in the gangway; unless otherwise prohibited by the authority.</p> <p>These buses can be operated for night and day service with the standard of ‘Direct Bus Service’. These buses can provide service for long, medium and short routes. These buses may have also various level of comfort class.</p>
Type III (Bus)	<p>These type of buses are those designed and constructed for inter-urban / inter-city transport without specified area for standing passengers, but can carry standing passengers over short distance in the gangway; unless otherwise prohibited by the authority</p> <p>These type vehicles are those designed and constructed for day bus service only and with the standard of ‘Normal Bus Service’. These buses can be operated for long, medium and short routes. The bus service is related to the frequent stops between origin and destination for passengers’ service. These buses may be made in any type of comfort level.</p>
Type IV (Bus)	<p>These type vehicles are those designed and constructed for special purpose. Schools buses, tourist buses and other buses used by institutions to transport their staff fall in this category. These buses may be made in any type of comfort levels.</p>
Low Capacity Vehicles	<p>This type includes Micro Bus: Seating capacity of maximum 14 passengers including driver. Mini Bus: Seating capacity between 15 to 25 passengers including driver. The body of Mini buses can be fabricated at the workshops with the various comfort level.</p>
High Capacity Vehicles	<p>These are the vehicles with seating capacity more than 56 passengers including driver. It includes an articulated buses used for Bus Rapid Transit.</p>
Standard bus (SB)	<p>Bus designed for basic minimum comfort level used for ‘Normal Bus Service’</p>
Deluxe Bus (DLX)	<p>A bus designed for a high comfort level and individual seats and adjustable seat backs, improved ventilation and pleasing interiors</p>
A.C. Deluxe Bus (ACX)	<p>A Deluxe Bus which is air conditioned.</p>
Door	<p>A sub system of a bus body that permits boarding and alighting of passengers. Door may or may not be with panel (hinged / sliding) for closing it.</p>
Service Door	<p>A door intended for use by passengers in the normal circumstances.</p>
Double Door	<p>A door affording two, or the equivalent of two, access passages.</p>
Sliding Door	<p>A door, which can be opened or closed only by sliding it along one or more rectilinear or approximately rectilinear rails</p>

Power operated Service Door	A service door which is exclusively operated by energy other than muscular energy and the opening and closing of which is controlled by driver or jointly by driver and crew member. In many cases requirement conductor (crew member) control may be necessary to operate the doors
Emergency Door	A door intended for use as an exit by passengers in an emergency only.
Exit	A service door or emergency exit
Emergency Exit	An emergency door, emergency window or escape hatch
Window	An aperture in the sides of the bus to let in light and air. The window need not necessarily be glazed
Emergency Window	A window, intended for use as an exit by passengers in an emergency only
Floor or Deck	That part of the body whose upper surface supports standee passengers, the feet of seated passengers and driver, and support the seat mountings
Gangway	It means the space providing access to passengers from any seat or row of seats to another seat or to any access passage; it does not include: The space required to accommodate the feet of the seated passengers; The space above the surface of any step or staircase; or any space which affords access to one seat or row of seats
Passenger Compartment	The space intended for passenger use excluding any space by fixed appliances or luggage/storage compartments
Driver Compartment	The space intended for the driver's exclusive use and contains driver seat, steering wheel, controls, instruments and other devices necessary for driving or operating the vehicle
Unladen kerb Mass	The weight of the vehicle in running order, unoccupied and unladen but complete with fuel, coolant, lubricant, tools and spare wheel
Seat	A structure complete with trim, capable of accommodating one or more adult person
Padding	The soft and resilient material installed between the seat frame sub-assembly and trim covering
Individual seat	A seat designed and constructed for the accommodation of one passenger
Double seat	A seat designed and constructed for the accommodation of two passengers side by side. Two seats side by side and having no interconnection shall be regarded as two individual seats
Continuous seat	A seat designed and constructed for the accommodation of two or more passengers side by side

Driver seat	The front seat intended for the seating of the driver.
Passenger seat	The seat intended for seating passengers
Seat Cushion	The part of the seat which is arranged almost horizontally and designed to support a seated passenger.
Seat-back	The part of the seat that is almost vertical, designed to support the passenger's back, shoulders and, possibly his head
Adjustment system	The device by which the seat or its parts can be adjusted to a position suited to the seated occupant
Locking System	A device ensuring that the seat and its parts are maintained in the position of use
Anchorage	A part of the floor or of the body of a vehicle to which a seat is fixed
Seat Frame	Structural portion of the seat assembly. The seat frame may be constructed with springs attached to the structural frame or may support padding
Seat Spacing	The distance between the front of a seat squab and the back of the seat squab of the seat preceding it, measured horizontally at a height of 620 mm above the floor
Integrated Head Restraint	A head restraint which can only be detached from the seat or the vehicle structure by the use of tools or by partial or complete removal of the seat covering meet the present definition
Detachable Head Restraint	A head restraint consisting of a component separable from the seat, designed for insertion and positive retention in the seat-back structure
Separate Head Restraint	A head restraint consisting of a component separate from the seat, designed for insertion and/or positive retention in the structure of the vehicle
Cab lamp or Courtesy lamp	A lamp/lamps situated above the head of the driver lighting up the dash board area and inside of the cabin. This is meant for operation while the bus is stationary. The cab lamp shall be capable of being operated only for a momentary duration while the bus is in motion
Exit Lamps	A lamp/lamps to light up the running boards. They are to light up automatically when the doors for exit or entry are opened. In the absence of closable doors at the entry and exit point, the lights are to be permanently lit during night operations of the bus
Locker lamps	A lamp/lamps to light up the inside of the locker when the door to the locker is opened, illuminating interior of the locker

Electrical distribution panel lamp	A lamp/Lamps to light up electrical distribution panel when the cover to the distribution centre is opened for checking and maintenance purposes
Instrument lighting lamps	A lamp/Lamps to light up individual instruments. These can be connected to a single control through a rheostat. By varying the control, the strength of the instrument lighting can be regulated by the driver while driving in the dark to avoid glare from instrument lighting
Control unit lamps	A lamp/Lamps are similar to instrument lighting. However, these lamps illuminate individual controls discreetly to assist driver for identifying the controls
Passengers area lamp	Lamps to light up the passenger area and assist passenger in identifying objects and reading the printed matter.
Gross Vehicle Weight	Technically permissible maximum weight, declared by the manufacture of the vehicle and certified by the testing agency

3. COMPONENTS OF BUS BODY STRUCTURE

Bus body structure is comprised of the following several structural elements. On the basis of the load bearing nature and the position of these elements these can be defined as shown in Figure 1.

Cross Bearers: These are structural members mounted on the chassis frame through ‘U’ Bolts or out rigger brackets. The cross bearers transmit the body load to the chassis and also withstand the forces induced during the normal operation of the vehicle

Vertical Pillars (Body pillar): These are structural members that support the roof structure and are connected to the cross bearers through gussets. The vertical pillars transmit load to the cross bearers and also withstand the forces induced during the normal operation of the vehicle.

Roof Arch Members: These are structural members that connect the vertical pillars and form a body section. In the event of a rollover, the body section absorbs the impact and provides survival protection in the passenger compartment. Gussets are also provided to improve the rigidity and strength of the body section.

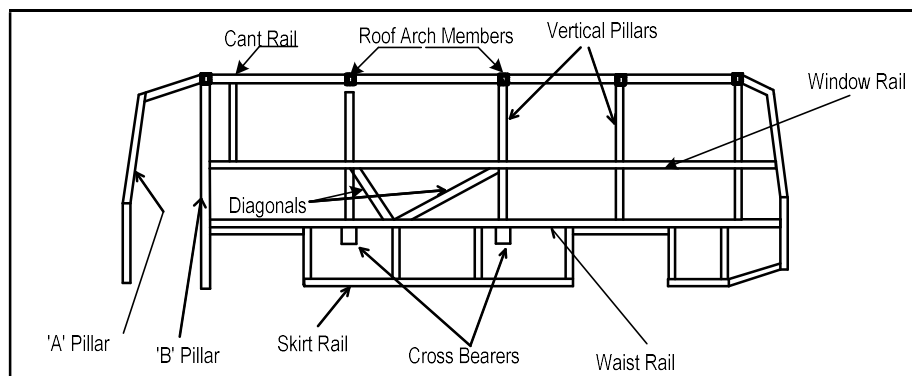

Figure 1 Bus Body Components

Cant rails: These are structural members that connect two body sections above the window section.

Waist Rails: These are structural members that connect two body sections below the window section.

Sole Bars: These are structural members that connect two body sections at the floor plane.

Seat Rails: These are structural members running along the lateral walls and provide support for seat mounting.

Floor Runners: These are structural members that connect cross bearers.

Roof Runners: These are structural members that connect roof arch members.

Out- Rigger Brackets: These are attachments that provide connection between the cross bearers and the chassis frame.

‘A’ Pillar: Any roof support forward of seating reference point.

Out- Rigger Brackets: are attachments that provide connection between the cross bearers and the chassis frame.

‘U’ Bolts: are fasteners used for fastening the cross bearers to the chassis frame.

Front Out-rigger Members: are provided to transfer load of Body structure members. These are fixed to the chassis side members. “A” pillars are supported on outrigger members such that the roof load is transferred to the chassis load bearing members. Further in the event of a collision the energy is absorbed by the pillars and the out riggers and minimizes the impact energy transmitted to the driver and passenger compartment. It provides the protection against frontal collision.

4. GENERAL REQUIREMENTS OF BUS BODY DESIGN

4.1 Categories of Buses and Services

Keeping in view the varying requirements and uses of buses and those of commuters, all buses are categorized into four types: Type I, Type II, Type III and Type IV, as defined the safe vehicle guidelines. Each of these types of buses is further categorized as Non-Deluxe (NDX) or standard bus, Deluxe (DLX) and AC Deluxe (ACX), on the basis of comfort level required by different categories of commuters. A chart depicting the categorization of buses and types of transport services are given in Figure 2.

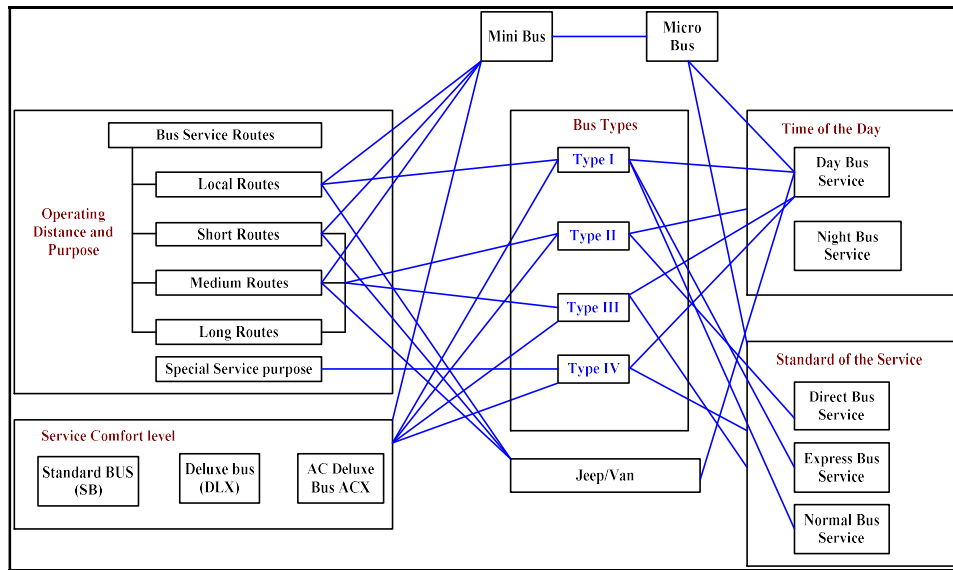

Figure 2 Bus Type and Transport Service

4.2 Overall Dimensions

Overall dimensions of the bus are given in the table below:

Table 1 General Dimensions of Various Kinds of Buses

Bus Category	Maximum length, m	Height, m	Width, m	Remarks
Type I	12	4.25	2.8	
Type II	10	4.25	2.8	
Type III	10	4.25	2.8	
Type IV	10	4.25	2.8	
Mini Bus	6	3.5	2.8	
Micro Bus	5	3.5	2	

4.3 Internal Dimensions

a. Service Doors

The service door(s) shall be situated on the side of the vehicle that is nearer to the side of the road corresponding to the direction of traffic. The minimum width of the service door shall be at least 650 mm. In case of buses where minimum two service doors are required, the front door shall be positioned either ahead of the front axle or behind the front axle, but necessarily in the forward half of the vehicle.

Type I bus requires two number of service doors with the minimum height of 1800 mm. The height of other type of buses is recommended as 1650 mm.

Minimum dimensions of service doors for the Mini buses shall be as follows:

Table 2 Dimensions of Door

	Standee	Non-standee
Height, mm	1650	1500
Width, mm	650	650

b. Window

Following factors shall be considered for the design of windows for the bus:

- The window panes shall be of sliding type for all buses except AC Deluxe (ACX) buses. However, in ACX buses the provision for adequate ventilation in case of Air Conditioning system.
- The minimum width of the window aperture (clear vision zone) shall be 550 mm.
- The minimum height of the sliding part of the window aperture (clear vision zone) shall be 550 mm for standard bus and 450 mm for Mini buses. However, this dimension is not applicable to ACX buses, where sliding window panes are provided for ventilation in case of A.C.
- In Type I Type II buses other than Mini buses, the minimum height of the window aperture (clear vision zone) shall be 1000 mm and the upper edge of the window aperture shall be at least at the height of 1700 mm from the floor. However, the height of the upper edge of the window aperture from the floor shall be at least 1500 mm in the rear saloon area for rear engine buses.
- In case of Mini buses, the minimum height of the window aperture (clear vision zone) shall be 450 mm and the upper edge of the window aperture shall be at least at the height of 1300 mm from the floor.
- The window aperture (clear vision zone) in case of ACX buses shall be at least 550 mm wide and 700 mm high. However, these dimensions shall not be applicable to the following – (i) Front & rear corner side windows. (ii) Any other window which forms a part of emergency exit. (iii) Fixed for the purpose of maintaining the minimum window pitch in relation to the overall vehicle dimension. (iv)The window (s) above route and destination box fitted at left side near the entrance, at eye level.

c. Emergency Exits

- In case of buses other than mini buses, at least one emergency exit shall be situated on the opposite side of the service door.
- In case of Mini Buses, the emergency exit shall be situated either on the opposite side of the service door or at the rear of the vehicle.
- In case of Mini Buses where the emergency exit is provided at the rear of the vehicle, its minimum dimensions shall be 1250 mm x 550mm for emergency door exit or 4000 square cm for emergency window exit.

- In case of more than one emergency exit, one of the emergency exits shall be situated in the front half of the vehicle, opposite to the service door and the second emergency exit shall be either on the rear half or at the rear side of the bus.
- If the driver compartment does not provide access to the passenger compartment by means of a passageway, the following condition shall be met:
 - The driver compartment shall have two exits, which shall not be on the same lateral wall; and one such exit is a window,
 - Where seats are permitted alongside the driver for passenger seat, both exits shall be doors. The driver door shall be accepted as emergency exit for the passengers and the second exit provided shall be accepted as the emergency exit for the driver, provided the driver controls, steering wheel, engine housing etc. do not constitute a serious obstruction.
- If the driver compartment and seats adjacent to it are accessible from the main passenger compartment by means of a passage, no additional external exit is required.
- The fitment of any welded structure / frame restricting the opening of any of the emergency exit, from inside or outside the vehicle, shall not be permitted.
- The minimum two numbers of emergency doors/ exits or apertures in case of other than Mini buses shall be provided. There shall be a minimum of one emergency doors/ exits or apertures in case of a Mini Bus.
- In case the driver door is easily accessible from the passenger compartment, the driver door may be considered as an emergency door.
- Minimum height and width of the emergency exit/door shall be of 1250 mm and 550 mm respectively.
- Minimum opening area of the emergency window should be of 4000 square cm.

d. Steps

All steps shall be provided with anti-skid surface (aluminium chequered plate/ grooved vinyl sheet or any non-slip coating). The anti-skid surface shall meet the requirements specified in AIS standard as and when notified

Dimensions of steps in mm shall be as given in the table below and shown in Figure 3 Dimensional Requirements for Steps.

Table 3 Dimension Requirements for Steps

Bus Type	Type I	Type II and Type III
First step from ground 'D' max. mm	340 (minimum depth 300mm)	380
Other steps 'E' max height, mm	250 (minimum depth 200 mm)	350

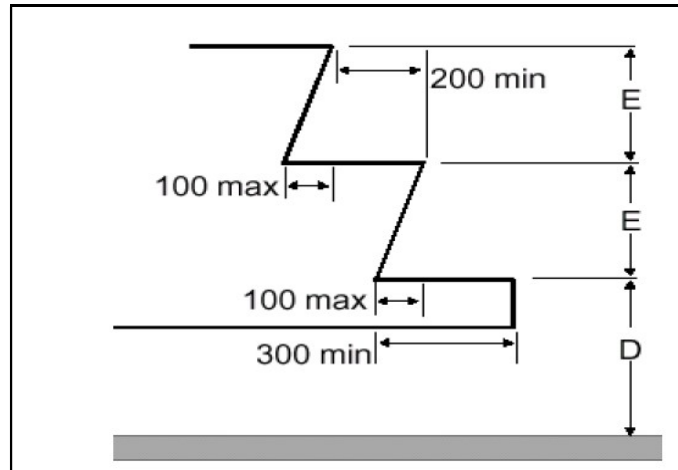

Figure 3 Dimensional Requirements for Steps

e. Gangway

The gangway for all the vehicle categories shall be designed and constructed to allow passage for passengers. The minimum width of the passage (gangway) shall be as below:

Table 4 The Minimum Width of the Passage (Gangway)

	Type I	Type II and Type III	Mini bus
Minimum width, mm	450	350	300
Minimum overall height, mm	1900	1900	1500

- The slope of the gangway with vehicle in the unladen condition and in the horizontal surface shall not exceed 6% in case of Type I, Type II and Type III.
- Gangways and access passages shall be covered/ lined with an anti-slip material. The anti-slip material shall meet the requirement of the relevant standard as and when notified.

f. Hand Rails Hand-Holds, Hand Straps

Handrails are attached to the ceiling of bus roof. The requirements for railing as well as for hand-holds are as:

- Handrails and handholds shall be capable of withstanding the force induced by sway of passenger (standard weight of 68 kg per passenger).
- They shall be designed and installed as to present no risk of injury to passengers. There shall be no relative movement between the rail and mounting bracket.
- Hand rails and hand holds section dimensions shall be such that the passengers can grasp them easily and firmly. Hand rail length shall be at least 100 mm to accommodate a hand.

Diameter of the section shall not be less than 20 mm and not more than 45 mm.



Figure 4 Typical Hand Holds

- In the case of handrails in access passage in Type II or Type III or non-standee mini buses and in case of handrails on doors and seats, a minimum sectional dimension of 15 mm shall be permitted provided that one other dimension is of at least 25 mm.
- The corners shall be rounded and devoid of sharp edges.
- The clearance between a hand rail or a handhold and adjacent part of the vehicle body or lateral wall shall be at least 40 mm. However in case of a handrail on a door or seat a minimum clearance of 35 mm shall be permitted.
- The lateral clearance shall be 150 mm minimum.
- Handrails and /or handholds shall be provided with sufficient number for each point of the floor area intended, for the standing passengers.
- For every position that can be occupied by a standing passenger, at least one of the two required handrails or handholds shall not be more than 1500 mm above the level of the floor at that position.
- Areas which are occupied by the standing passengers and are not separated by seats from the side walls or rear wall of the vehicle shall be provided with at least two horizontal handrails parallel to the walls and installed at a height between 800 mm and 1500 mm above the floor.

g. Hand Rails and Hand Holds for Service Doors

- Door apertures shall be fitted with Hand Rails and/or Hand Holds on each side. Handrails and Handholds provided for service doors shall be such that they include a grasping point available to a person standing on the ground and adjacent to the service door or any of the successive door steps. Such point shall be situated, vertically,

between 800 to 1000 mm above the ground or from the surface of each step, and horizontally,

- For position appropriate to the person standing on the ground, not more than 400 mm inwards from the outer edge of the first step, and
- For position appropriate to the particular step not more than 400 mm inward from the inboard edge of that step and not outwards from the outer edge of the step considered.

h. Guarding of Step-Wells

Where a seated passenger is likely to be thrown into a step-well as a result of heavy braking, a guard shall be provided. The guard height shall be minimum 800 mm from the floor, and the guard shall extend inward from the wall at least 100 mm more than the center line of the seating position of the passenger who is prone to this risk or up to the edge of the riser of the innermost step, whichever is higher in dimension.

i. Seats

All the seats shall be installed facing forward, except in case of **Type I** standard buses where - rear facing seat behind the driver, side facing seats on the rear wheel hump, shall be permitted.

Seat Layout: In general 2x2 type of layout is recommended for all type of passenger buses.

Driver Seat: Driver seat shall comply with the requirements specified by the vehicle manufacturer company.

Passenger seats: Seat width: The minimum width of a seat cushion, measured from the vertical plane passing through the center of that seating position shall be as:

Table 5 Width of Seat Cushion

	Type I and Type II and Mini buses	Type III
Width of seat Cushion on each side In mm	200	225

The minimum width of the available space for each seating position, measured from a vertical plane passing through the center of that seating position between heights of 270 and 650 mm above the uncompressed seat cushion, shall be:

- 250 mm in the case of individual seats, and
- 225 mm in the case of continuous seats for two or more passengers
- For vehicles 2.35 m in width or less, the width of the available space for each seating position shall be 200 mm.
- For vehicles having a capacity not exceeding 22 passengers, in the case of seats adjacent to the wall of the vehicle, the available space does not include, in its upper part, a triangular area 20 mm wide by 100 mm high.
- In addition, the space needed for safety belts and their anchorages and for the sun visor should be considered as exempted.

- For vehicles above 2.35 m and up to 2.6 m in width, with 3X2 seating layout, the minimum width of available space for each seating position shall be 200 mm.
- The minimum backrest height (H): This is expressed as the vertical distance between the floor and the top of the seat or headrest. The dimension shall be as:

Table 6 Backrest Height, mm

	Type I	Type II	Type III
Minimum backrest height (H), mm	800	1000	1100

Minimum armrest height from cushion (if provided) is recommended as 175 mm. The minimum armrest width, wherever provided shall be as follows:

Table 7 Minimum Armrest, mm

	Type I	Type II	Type III
Minimum armrest width, mm	40	40	50

j. Cabin Luggage Rack:

All buses except **Type I buses** shall have cabin luggage racks. The minimum dimensions of the cabin luggage rack shall be as given below.

Table 8 Minimum Dimensions of Cabin Luggage Rack

	Type I	Type II and Type III	Minibus
Width from Side wall (in mm)	250	350	250
Height from Roof (in mm)	200	250	200

The cabin luggage racks shall be designed in such a way that the luggage is prevented from falling in the event of sudden braking or due to forces generated during cornering.

Table 9 Dimensions of Roof Access Ladder

Dimension, mm	Minimum	Maximum
Height of first step above ground (A)	-	700
Step Height (B)	230	300
Width	150	-
Rung Diameter or width (D)	25	-

4.4 Destination Board for Public Service Vehicles

Minimum of three destination boards shall be provided in **Type I bus** with at least one destination board each on front, rear and the service door side of the bus. However, in the case of Mini buses at least two destination boards shall be provided.

Type II and Type III minimum two destination boards shall be provided with one in the front and on in the rear. The minimum dimensions of the destination board shall be as given in Table 10

Table 10 Size of the Destination Board

Location	Height, mm	Width, mm	Minibus	
			Height, mm	Width, mm
Front	220	1800	200	800
Rear	220	900	200	800
Service door side	220	900	200	800

The destination board shall be illuminated such that the whole of the destination board and the writing thereon are legible at a minimum distance of 30 meters.

4.5 Driver's Work Area

Buses other than Mini Buses shall meet following driver's work area requirements.

Driver Door: All buses with the front engine shall be provided with a driver door. In the case of Rear Engine Buses, no separate driver door shall be required, provided that the conditions for minimum number of emergency exits are provided. The minimum height of the driver door aperture, i.e., clear opening excluding handles, measured from the bus floor in the driver's area, shall not be less than 1250 mm high and 650 mm wide. In case of Mini buses, this dimension shall be 1050 mm high and 650 mm wide.

Climb Facility: The maximum height of first step from the ground shall be 550 mm. The maximum height of other steps shall be 250 mm. The maximum number of steps shall be three. The minimum step width shall be 150 mm. Minimum step depth shall be 150 mm. The steps need be provided with anti-slip surface.

Hand Holds: The driver door aperture shall have minimum two handholds with one on each side. The hold on the left-hand side shall be positioned such that the lower edge of the grip is at a height not more than 1600 mm. The right side handhold shall be located at a height not greater than 2168 mm from the floor level. The cross section of the hand hold shall not be less than 20 mm and not more than 38 mm in diameter. In case of rectangular sections, the size of the section shall be of size 25 mm by 15 mm. The corners of the hand holds need to be rounded and smooth. Hand clearance to the mounting surface i.e. the gap for inserting the palm shall not be less than 30 mm. The hand holds shall meet the requirements for the strength as notified. The handholds shall be placed such that the projection will not cause injury while climbing in or out through the door. No sharp corners, pointed edge shall be permitted.

Work Area Dimension: The minimum width of the driver area from the right side wall shall be 800 mm, at a height of 900 mm from the heel point horizontal plane. The minimum distance of driver partition from the driver seat shall be 25 mm from the rearmost point of the driver seat in its rearmost position with seat back reclined backwards to an angle of 12 degrees. All dimensions and reference planes are shown in Figure 6.

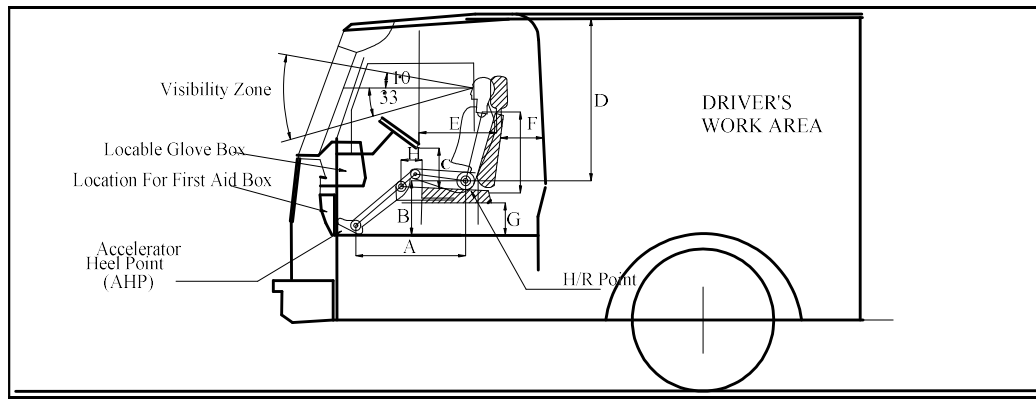

Figure 5 Driver's Work Area Requirements

Table 11 Dimension Requirement for Drivers' Work Place

A	Distance from heel point to H point	600 mm to 640 mm
B	Minimum distance from floor to H point	500 mm
C	Thigh Clearance	200 mm to 260 mm
D	Minimum distance from H point to roof top	1060 mm
E	Minimum distance from the lower end of steering to the front of driver's seat backrest	250 mm
F	Minimum distance of driver's partition from the rear of the driver's seat with the driver's seat in the rear most position	25 mm

Position of Steering Wheel: The chassis manufacturer shall specify the position of the steering wheel with reference to the heel point. The minimum distance of lower end of steering wheel from driver seat back shall be 350mm.

The placement of instrument panel shall be such that the primary instruments and controls are visible unobstructed while viewed from the driver seat. The dashboard shall be of non-metallic, fire resistant, energy absorbing material and so constructed that in the event of a collision it shall cause no or minimum injury to the driver.

4.6 Standee Passenger Area

The capacity of standee passengers to be allowed in a bus will be governed on the basis of free bus floor area available for standee passengers by calculating at the rate of six standee passengers per square meter. The surface area "Asp" available for standee passengers will be calculated after deducting the following from the total floor area of the vehicle:

- The area of driver's compartment i.e. the space intended for driver's exclusive use and containing the driver's seat, the steering wheel, control, instruments and other devices necessary for driving or operating the vehicle. The area of steps at door and the area of any other step with a depth of less than 30 cm and the area swept by the door and its mechanism when it is operated.

- The area of any part over which the vertical clearance is less than 135 cm. e.g. above wheel arch and above the engine, measured from the floor, according to the specified method and disregarding permitted intrusion.
- The area of any part of the vehicle to which access to passengers to be prevented for safety or any other reasons e.g. space available on both sides of the driver.
- The area of floor space reserved solely for carriage of goods and luggage and from which passengers are excluded.
- The area of all parts which are not accessible to a standee passenger.
- The bus floor space of 150mm width along the bus gangway for facilitating movement of the passengers / conductor.

4.7 Provisions for Disabled Passengers

All types of buses shall have at least two passenger seats designated as priority seats for persons with disabilities. These seats shall be only of the forward facing type and preferably be located behind the driver's seat. The seats designated for disabled passengers shall be indicated with appropriate sign(s). The priority seats shall be provided with appropriate facility for securing the crutches, canes, walkers etc. to facilitate convenient travel for persons with disabilities.

5. TECHNICAL AND SAFETY REQUIREMENTS

5.1 Body Structure Strength

The body structure of all single deck buses of Type II and Type III category excluding Mini Buses, shall be of sufficient strength, to meet the test requirements in Chapter 9.

5.2 Body Structure Stability

The stability of the body structure on the vehicle chassis shall meet the requirements of the stability test defined in Chapter 9.

5.3 Joint Strength

Body panel joints shall be capable of meeting the requirements specified in Chapter 9.7.

The structure of the door shall be able to withstand distortion due to forces induced during its operation and the operability of door components critical to the removal of the passengers after an accident shall be ensured.

The external side of the door shall not have any projection and the hinges and door handles shall be recessed.

Door shall be fitted with weather resistant rubber seals of suitable design to avoid dust and water ingress.

5.4 Service Doors

All Type I buses, except service door shall be provided with Power Operated Service Door(s). Type II & Type III buses shall be provided with Power Operated or Manually Operated Service Doors(s).

Service door shall be capable of being easily opened from inside and from outside the vehicle when the vehicle is stationary. However, this requirement does not preclude the possibility of locking the door from the outside, provided the door can be always opened from inside.

The control or device for opening a service door from the outside shall be located at a height of 1150 mm to 1250 mm from the ground level. The measurement shall be carried out in the unladen condition on level surface.

Single piece manually operated service door which is hinged or pivoted shall be such that in the event the open door comes in contact with an external object while the vehicle is in forward motion the door shall tend to close. Where direct view is not adequate, optical or other devices shall be installed to enable the driver to detect from his seat the presence of a passenger in the immediate interior or exterior vicinity of every service door. On the inside of a service door there shall not be any device intended to cover the inside steps when the door is closed. The door operating mechanism and other equipment attached to the inside door should not pose safety hazard for the passengers.

For every door which opens inwards, the mechanism shall be so constructed that its movement is not likely to cause injury to the passengers during normal use.

Additional Requirements for Power Operated Service Doors: In the event of an emergency every power-operated door shall be capable of:

- being opened from inside when the vehicle is stationary even when locked from outside, by controls with or without power supply by which the door normally operates.
- being operated by a single person easily by hand.
- The controls shall be easily seen and identified by a person approaching the door or standing in front of the door.
- The interior controls are placed on or within 300 mm of the door, at a height between 1500 mm to 1600 mm above the first foot step. The construction and control system of every power operated service door be such that a passenger is unlikely to be injured by the door or trapped between the doors while closing.
- The door system shall meet the test requirements defined in Test methods.

5.5 Emergency Doors

The emergency doors shall be capable of operation from both inside and outside when operated manually. However this requirement shall not be construed as precluding possibility of locking the door from outside provided the door can be opened from inside. The outside handles of emergency doors shall lie within 200 mm on either side of centerline of the door drawn in the horizontal plane. However, the position of the outside handle shall not be more than 1800 mm above the ground level in the unladen condition. Doors shall be hinged at the forward edge and in case of horizontal door the hinge shall be on the top edge. Emergency doors shall not be power operated or of sliding type. Emergency doors shall open outward and shall be capable of remaining open outwards and at an angle of at least 100 degree, such that aperture is clear of any obstructions. All emergency doors shall be provided with an audible device to warn the driver when the emergency doors are not securely closed.

The warning device shall operate due to the movement of the door catch and not by the movement of the door itself.

5.6 Emergency Windows

All hinged or executable emergency window shall open outwards. Emergency window shall be capable of being easily and instantaneously operated from inside and from outside the vehicle. Emergency window shall be also made of readily breakable safety glass. In such case a device shall be provided adjacent to each emergency window, available to the person in the vehicle for ready access for breaking the window. The window glass shall be made of safety glass and shall readily break on impact when hit by a hammer in the event of an emergency. Every emergency window which can be locked from outside shall be constructed such that it shall be capable of being opened at all times from inside. Emergency window where horizontally hinged at the top edge shall be provided with a suitable stay to hold the door fully open. Every emergency window shall operate such that it does not obstruct clear passage. Every hinged emergency window which is not visible from the driver's seat shall be fitted with an audible warning device to warn failure of locking system

5.7 Escape Hatches

Escape hatches shall be ejectable, hinged or readily breakable safety glass. Operation of escape hatch shall not obstruct clear passage from inside or outside the vehicle. Escape hatches shall be capable of being easily operated from inside and from outside the vehicle. However this requirement shall not be construed as precluding possibility of locking the escape hatch from outside for the purpose of securing the vehicle when unattended provided the escape hatch can be always opened from inside the vehicle. In case breakable safety glass is provided, a device shall be provided for breaking the escape hatch.

5.8 Marking of Emergency Exits:

All emergency exits shall be prominently designated in red letters in English as also in the Nepali language.

5.9 Door Components

All door components shall meet the requirements specified as mentioned below:

Table 12 Door Component Standards

Description	Standard
Automotive Vehicles :locking systems and door retention components: general requirement	IS 14225-1995 or equivalent
Automotive Vehicles:-window retention and release systems for buses	IS 13944-1994 or equivalent

Note: Body builder should have the manufacturers' certificate of standard

5.10 Windows

The window glass shall be made of safety glass as specified in IS 2553 Part 2 or its equivalent and shall readily break on impact when hit by a hammer in the event of an accident.

The edge shall be crown edge, satin finish for all exposed edges that is likely to come into touch with the passenger's body. The glazing may be mounted on frame constructed from aluminum extrusions or formed steel /coated sections.

The window frame shall be attached to the structure by weather strips or bonded with adhesive or any other suitable method.

5.11 Ingress of Dust And Rain Water

All body joints, front safety glass, rear safety glass, doors, windows and hatches should be so constructed such that it does not permit ingress of rain water, in the fully closed condition. It is recommended that the bus body builders carry out their own internal assessment test to check water proofing.

All body joints, front safety glass, rear safety glass, doors, windows and hatches should be so constructed such that it does not permit ingress of dust, in the fully closed condition. It is recommended that the bus body builders carry out their own internal assessment test to check dust ingress.

Drain holes shall be provided in the window frame such that water shall flow outward and does not flow into the structure cavity or into the passenger compartment.

5.12 Body Insulation

Body insulation shall be provided with suitable material for DLX and ACX buses and optional for other categories. It is recommended to use materials like Polyurethane or Glass Wool of minimum thickness of 40 mm and minimum density of 40 kg/m³. Materials superior to the ones shall also be permitted.

5.13 Rear View Mirrors

The rear view mirrors shall meet the requirement of the relevant standard as and when notified by DoTM.

5.14 Wind Screen Wiping System and Driver's Field of Visions

The wind screen wiping system shall meet the requirements of the relevant standard as and when notified by DoTM. All types of buses shall meet the requirements of driver's field of vision specified in the relevant standard as and when notified by DoTM.

5.15 Vehicle Seats and Seat Belts

All Seat designs and Seat anchorage designs used in buses, shall meet the requirements of the relevant standard as and when notified by DoTM as amended from time to time. The seat belts assemblies and their anchorages shall meet the requirements of the relevant standard as and when notified by DoTM. The Seats used in buses shall be those which are type approved by the testing agency. Document for this compliance shall be made available when asked by the authority like DoTM.

5.16 Strength Roof Luggage Carrier

- The RLC platform shall be able to withstand:
- Uniformly distributed static load of 150 kg / m²
- Inertia forces equivalent of 2.5 g.
- Shear force equivalent to 1.5g.
- RLC structure, its mountings and the bus roof structure integrity in relation to RLC need to be type approved both at design stage as also at prototype type approval stage.

5.17 Bumpers

- Bumpers and their mounting arrangements shall be provided on both front and rear of the vehicle, and made of steel or impact resistant polymer or combination of both and shall meet the requirement of the relevant standard as and when notified.
- The front and rear of the vehicle shall be protected in such a manner that in the event of a low speed collision the damage to the vehicle is minimum.
- The edge of bumper shall be turned inwards and shall be devoid of sharp corners capable of causing injury.
- Plastically deformable retaining elements located between the body structure and bumper shall be permitted as energy absorbers in addition to the steel sheet component.
- Suitable gap between the bumper and the body shall be given such that in the event of a frontal or rear collision the body panels are subjected to minimum damage.

5.18 Corrosion Protection

The quality of the surface treatment shall be tested according to the test methods specified in JIS D0202 or equivalent BIS standard. (General Rules of Coating Films for Automotive Parts or equivalent Indian Standards using test panels) or other equivalent standard.

5.19 Protection against Fire Risk

Engine Compartment: No flammable sound proofing material or material liable to impregnated with fuel, lubricant or any combustible material shall be used in the engine compartment unless the material is clad by an impermeable sheet. Precaution shall be taken, either by suitable layout of the engine compartment or by provision of drainage orifices to avoid as far as possible, the accumulation of fuel, lubricants or any other combustible material in any part of the engine compartment.

A partition of heat-resistant material shall be fitted between the engine compartment and any other source of heat (e.g. a retarder designed to absorb energy liberated when descending along gradient). Any device designed for employing warm water shall be precluded from this requirement. All mounting clips gaskets etc. used in conjunction along with the device shall be fire resistant.

5.20 Fuel Filler Apertures:

Fuel filler apertures shall be accessible only from exterior of the vehicle.

5.21 Fuel Tank:

Position of filler aperture shall be as fitted by the vehicle manufacturer. Alteration/ relocation of the fuel tank shall not be permitted unless approval obtained from the vehicle manufacturer and test agency.

No part of the fuel tank shall project beyond the overall width of the body work.

5.22 Fuel Feed System

Alterations shall not be permitted on fuel feed system provided by the vehicle manufacturer. The coach builder shall obtain Type approval for carrying out any modification prior to any alteration if deemed necessary.

No apparatus used for the fuel feed shall be placed in the driver's compartment or the passenger compartment. Fuel lines and all other parts of the fuel feed shall be accommodated in the vehicle where they have the optimum protection.

It is recommended that twisting and bending movements and vibrations of the vehicle or the power unit do not subject the fuel lines to abnormal stress. It is also recommended that the union of pliable pipes with rigid parts of fuel feed system must be so designed and constructed as to remain leak proof in various condition of use of the vehicle despite ageing, twisting or bending movements, or vibration of the vehicle structure or power unit. Fuel leaking from any part of the engine system be able to flow away freely to the road surface, but never into the exhaust system.

5.23 Fire Extinguishers

The vehicle shall be equipped with one or more fire extinguishers, one being near to the driver's seat. Fire extinguishers shall comply with IS: 13849 or IS 2171 or other equivalent standard. Type and the minimum number of extinguishers to be provided shall be as follows:

Table 13 Type and the Minimum Number of Extinguishers

Total Capacity of Fire Extinguisher	Standard Bus	Mini Bus
4 kg rating for Standard Bus and 2 kg rating for Mini Buses	Minimum two fire extinguisher of 2 kg each, totaling to 4 kg.	Minimum two fire extinguisher of 1 kg each, totaling to 2kg

Halogenated hydrocarbon type of extinguisher shall not be used as extinguisher. The Fire extinguishers shall be secured against tampering and shall be kept in lockers or behind breakable glass. The location shall be marked clearly.

5.24 First Aid Equipment

First Aid Kits shall be provided containing items for primary treatment. Space shall be provided for fitting more than one first-aid kit. The First Aid Kits shall be secured against tampering and shall be kept in lockers or behind breakable glass. The location shall be marked clearly.

5.25 Modification of Chassis And / or Chassis Related Components

Alterations shall not be permitted on the chassis or any of its aggregates or components. Any modifications shall call for fresh type approval of the design and the prototype.

5.26 Air Conditioning (AC) System

The A.C. system shall meet the technical and safety requirements as and when notified.

6. LIGHTING AND ILLUMINATION

6.1 Lighting, Signaling and Indicating Systems

External: External lighting, signaling and indicating systems of the bus shall comply with the relevant standard of the manufacturing country.

All equipment and devices shall be Type Approved.

Internal: Lighting, signaling and indicating systems shall provide adequate illumination inside the bus for the safe operation by the driver and the passengers, during darkness and other conditions of reduced visibility.

6.2 Position of Illumination Devices

The following lamps are to be placed on the roof of the bus, above the head of the observer:

- Cab lamp or courtesy lamp
- Passenger area lamps
- Exit lamps are to be placed at the foot level.
- The following lamps are to be placed inside the compartment/unit/control:
 - Locker lamp
 - Electrical distribution Centre lamp- Instrument lighting
 - Control unit lamps

6.3 Type of Bulbs for Lamp Assemblies

The following lamp assemblies can be illuminated either by incandescent bulbs or L.E.D (Light Emitting Diodes):

- Tail lights
- Instrument lights
- Control unit lamps

The following lamp assemblies can be illuminated by incandescent bulbs:

- Electrical distribution center lamp
- Locker lamp

The following lamp assemblies can be illuminated by incandescent bulbs or fluorescent bulbs:

- Entrance lamps
- Cab lamp or courtesy lamp
- Passenger area lamp

6.4 Photometric requirements

Lighting requirements of the lighting, signaling and indicating systems for the following sub groups:

- Dash Board Tell tale lighting/Control lighting
- Driver Cabin lighting
- Passenger Compartment lighting
- Other Area lightings

Lamps falling in this category:

- Instrument lighting
- Tell-tale lighting
- Control unit lamps

The illumination by lighting devices lighting up dash board instruments, tell tales and controls shall be discreet and shall not disturb the driver when driving in the dark.

The strength of the instrument lighting shall be capable of regulation through a rheostat or any other suitable means. The illumination intensity of all the lamps provided for lighting instruments, controls inside the cabin shall not be more than 10 candelas and shall not be less than 2 candelas.

6.5 Driver Cabin Lighting

The following lamps fall in this category:

- Cab lamp or courtesy lamp
- Locker lamp
- Electrical distribution lamp

The illumination by lighting devices lighting up the cabin interior should be sufficient enough to clearly distinguishing each component part of the cabin. Driver should be in a position to read signs written on the walls, door of the cabin. He should also be in position to read any instructions printed on paper.

The luminous flux of all the lamps provided for cabin lighting to light up the equipment, components and to read, shall not be less than 100 lux and shall not be more than 150 lux at the point of observation and as seen by the driver. The driver's compartment shall be provided with illumination through separate circuit.

6.6 Passenger Compartment Lighting

The following lamps fall in this category:

- Exit lamps
- Passenger area lamps

The illumination by lighting devices lighting up the passenger area should ensure reading of signages inside the passenger area and other important signs like emergency signs. The illumination should light up handles, latches, knobs, rods, hand-holds, etc facilitating easy access to passenger. It should be adequate for reading printed matter like newspaper.

The illumination of these lamps shall not be less than 150 lux, when measured at any seating location of the bus and at the eye level of the seated passenger , i.e at 620 mm above the seat base.

At least two night lights spaced at 2 m to each other shall be provided in the passenger compartment. The interior lighting shall be designed such that the glare and reflections caused does not affect the driver.

6.7 Other Area Lightings

Luggage hold area lighting: Every luggage hold shall be provided with light fittings for illuminating the hold when in use.

Destination panel lighting: The front, rear and side (optional) of the vehicle shall be illuminated and the inscription on the panel/board shall be visible at a distance of 30 m.

Side marker lamp: These are to be mounted on the side of the vehicle and shall be of amber colour. They shall be mounted on a height of 800- 1200mm above the ground.

6.8 Type Approval

The number of lamps, their position, type and wattage used shall be type approved.

All the above information shall be incorporated in the technical specification submitted for the type approval.

7. ELECTRICAL EQUIPMENT AND WIRING

7.1 Electrical Cables

All cables used shall be marked with the relevant standard. Copper conductors with fire retardant PVC insulation and able to withstand working temperature up to 70°C shall be used. All the cables shall be ducted and secured at suitable places in such a manner that during normal use of vehicle the cables are not subjected to any tension, stretching, and nicking, cutting, abrasion or chaffing.

The conductor cross section shall be selected to carry the rated current as given below:

Table 14 Specification for Low Tension Wire for Automobile Application

Allowable Current (A)	Number/ Diameter of wire in (mm)	Cross Sectional Area in (mm ²)	Outer Diameter (mm)	Finished Outer Diameter (mm)
9	7/0.32	0.5629	1.0	2.2
12	11/0.32	0.8946	1.2	2.4
15	16/0.32	1.267	1.5	2.7
20	26/0.32	2.081	1.9	3.1
28	41/0.32	3.287	2.4	3.8

7.2 Fuse

Every electrical circuit shall be provided with fuse designed for the circuit. In case of multiple circuits a common fuse shall be permitted, subjected to maximum current capacity of 15 Ampere per circuit. The current carrying capacity of the fuse shall be:

Rated Current of Fuse = 1.5 times the Load Current of the Electrical Equipment

7.3 Terminals, Connectors & Elements

End terminations: All the ends shall be suitably crimped with lugs /soldered or fixed so as to withstand vehicle vibrations. The interconnection shall be through couplers/junction boxes/terminal blocks.

Weatherproof connectors shall be used for external areas which are exposed to atmosphere to avoid water /moisture ingress during use.

7.4 Safety Requirements

Use of relays and other electrical elements shall be adopted where the current rating of the switches is not adequate. The additional circuits shall not draw current more than specified by the manufacturer. Where the voltage exceeds 100 Volts RMS (Root Mean Square) in one or more electrical circuit, a manually operated isolation switch which is capable of disconnecting

the circuit(s) from the main electrical supply shall be provided and shall be located inside the vehicle in a location easily accessible to the driver. No circuit provided by the vehicle manufacturer or type approved shall be modified.

The isolation circuit shall have provision of bypassing circuits supplying mandatory external vehicle lighting. Electrical cables shall be located such that no part can make contact with any fuel line or exhaust system subjected to excess heat. Suitable special insulation shall be provided where such electrical circuits are necessary. Electrical conductors shall meet the requirement for flame resistance specified in the standard as and when notified by DoTM.

7.5 Batteries

All batteries shall be well secured and easily accessible. The battery compartment shall be separated from the passenger compartment and driver's compartment. It shall be well ventilated. Battery terminals shall be protected against short circuit risk.

Isolation Switch: A manually operated isolation switch, which is capable of disconnecting the battery terminal from the electrical circuit, shall be provided.

7.6 Type Approval

The circuit diagram for the bus shall be type approved. Calculations in arriving at conductor size, fuse rating, switch rating shall form a part of type approval requirement. The number of lamps, their position, type and wattage used shall also be type approved.

All the above information shall be incorporated in the technical specification submitted for the type approval.

8. BUS BODY TEST METHODS

8.1 Design of Bus Bodies

All bus body builders may adopt suitable tools to design bus bodies for sufficient strength and for all the performance parameters specified in the guideline. Bus Body Builders may have their own analysis of bus body structures, done by use of Finite Element Analysis (FEA) or any other analytical tool to ensure sufficient bus body strength, for specific compliance to the strength requirements given at below. FEA is a detail design tool which basically saves time in designing and produces more accurate results. It is therefore recommended that bus body builders use design tools such as FEA, for verifying the strength of the bus body superstructure, either by themselves or from the authorized test agencies. FEA would greatly help in assessing physical compliance at the design stage itself.

8.2 Body Structure Strength Test

All single deck buses of excluding Mini Buses, shall meet the requirements specified below.

The body structure of the vehicle shall be of sufficient strength, to ensure that during and after it has been subjected to the test specified below in 9.3.

No displaced parts of the vehicle intrudes into the residual space

No part of the residual space projects outside the deformed structure. The residual space means the space to be preserved in the passenger compartment during and after the structure has been subjected to roll over test. The space is defined as the volume within the passenger compartment when swept by a transverse plane defined in Figure 6 is moved in straight line or lines such that it passes through the

“R” points of all the passenger seats (from rear through intermediate to foremost seat illustrated in Figure 7.

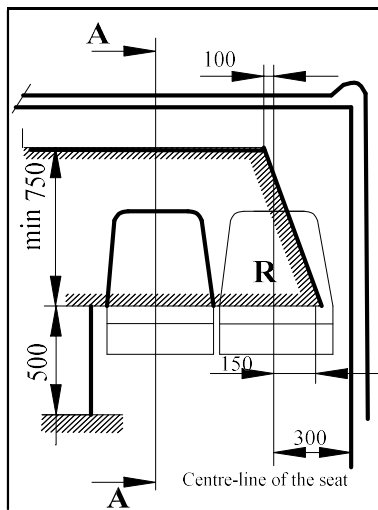

Figure 6 Residual Space After Lateral Intrusion

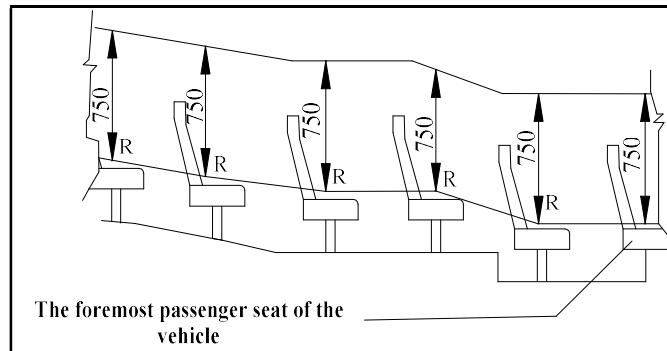

Figure 7 Sectional View At A-A

For the purpose of above rule the “R” point defined in Figure 6 shall be assumed to be 500 mm above the floor under the passenger’s feet, 300 mm from inside of the side of the vehicle and 100 mm in front of the seat back in the centerline of the outboard seats.

8.3 Test Methods

Each type of vehicle shall be subjected to the Roll-Over Test on complete vehicle or on a body section (s) representative of the vehicle or alternate method approved by the test agency.

8.4 Acceptance Criteria

If the body structure tested meets requirement defined in guidelines then the structure shall be considered to comply with the requirement.

8.5 Roll-Over Test on a Complete Vehicle

a. Test Conditions

While the vehicle need not be fully finished condition, it shall be representative of production vehicles in respect of unladen kerb mass, centre of gravity and distribution of mass as declared by the manufacturer.

Driver and passenger seats shall be placed with their backs, if adjustable, in their most upright position. The height of the seats, if adjustable shall be at the highest position.

Every door and opening window of the vehicle shall be closed and latched but not locked.

Tires shall be inflated to the pressure prescribed by the vehicle manufacturer and, if the vehicle has a pneumatic suspension (air Spring) system, the pneumatic spring air pressure shall conform to vehicle manufacturer recommendation. Any automatic leveling system shall be adjusted with the vehicle on a

flat, horizontal surface to the level specified by the manufacturer. Shock absorber shall operate normally

Fuel, battery acid and other combustible, explosive or corrosive material may be substituted by other materials.

The impact area shall consist of concrete or other rigid material.

b. Test Procedure

The vehicle shall be placed on a platform in order to be rolled over on one side (Figure 8). This side for the roll over shall be the weaker of the two sides, as brought out during design type approval stage.

The position of the vehicle on the platform shall be such that when the platform is horizontal:

The axis of rotation is parallel to the longitudinal axis of the vehicle,

The axis of rotation is 0 – 200mm from the vertical step between the two levels,

The axis of rotation is 0 – 100mm from the side of the tyre at the widest axle,

The axis of rotation is 0-100 mm below the 0 – 100mm horizontal sitting plane on which the tyre stands and

The difference between the height of the horizontal sitting plane and the horizontal lower plane on which impact takes place shall not be less than 800 mm.

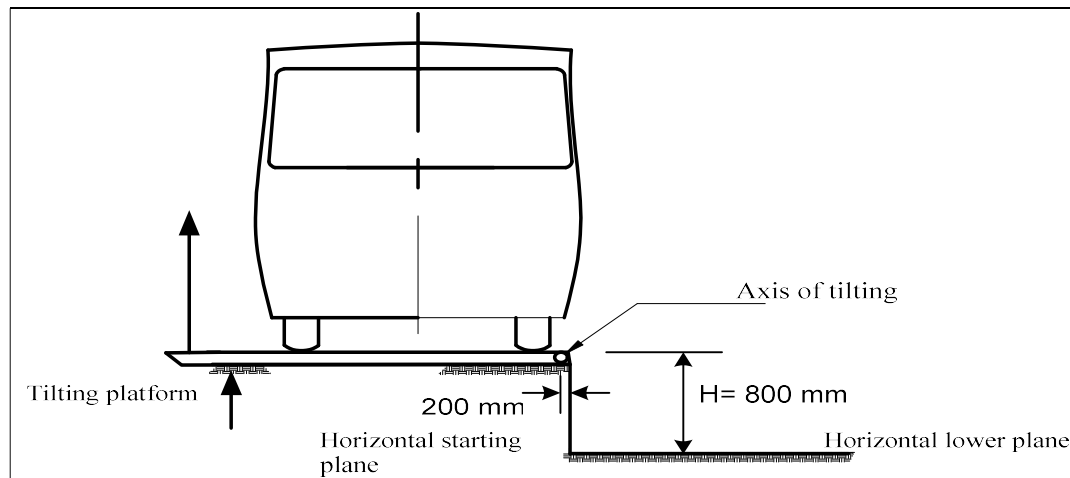

Figure 8 Test Setup for Rollover Test

Means shall be provided to prevent the vehicle moving along the longitudinal axis.

The test apparatus shall prevent the tyres from sliding sideways in the direction of the roll over by means of side walls.

The test apparatus shall ensure the simultaneous lifting of the axles of the vehicles.

The vehicle shall be lifted without rocking and without dynamic effects until it rolls over. The angular velocity shall not exceed 5 degree per second (0.087 rad/sec).

High speed photography, deformable templates or other suitable means shall be used to determine that the requirement has been met. This shall be verified at not less than two positions, nominally at the front and the rear of the passenger compartment, the exact positions being at the discretion of the test agency. Template shall be fixed to substantially non-deformable parts of the structure.

8.6 Stability Test

Test Requirements; When the surface on which the vehicle stands were tilted to both sides in turn at an angle of 28 degrees from the horizontal the vehicle shall not overturn.

a. Test Condition

For the purpose of test the vehicle, the unladen vehicle with addition of:

Load equal to 75 kg (68 kg standard mass of passenger + 7kgs luggage) shall be placed on each passenger and crew seat. Where vehicle is designed to carry standee passengers a load of 75 Kg. is placed with its centre of gravity at a height of 875 mm from the floor. The load shall be uniformly distributed.

Where vehicles are designed and constructed to carry luggage on the roof, a uniformly distributed mass not less than of 150 kg/ m² representing the luggage, shall be secured to the roof.

Alternatively a calculation method may be used to prove that the vehicle will not overturn under above mentioned conditions. The Calculation method shall be approved by the test agency. The coach builder shall establish the validity of the calculation method to the satisfaction of the Test Agency on the basis of comparative test with a similar vehicle.

b. Test Method

The vehicle shall be subjected to test on a tilt test rig. Height of step used to prevent the vehicle from slipping sideways on the test rig shall not be greater than two third of the distance between the surface on which the vehicle stands and part of the rim of the wheel which is nearest to the surface in the untilted position as shown in Figure 9.

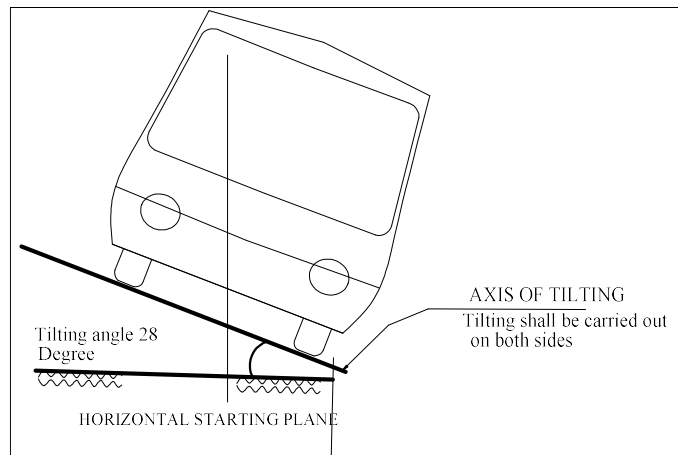

Figure 9 Test Setup for Stability Test

c. Acceptance Criteria

The stability of a vehicle shall be considered to comply with the requirement if the angle at which overturning occurs is greater than 28 degrees from the horizontal.

8.7 Joint Strength Test

Each body panel joint shall be capable of holding the body panel to the member to which it is joined when subjected to a force of 60% of the tensile strength of the weakest joined body panel as per the test procedure given below.

8.8 Test Procedure

Preparation of the test specimen: If a body panel joint is 203 mms long or longer, cut a test Specimen that consists of any randomly selected 203 mm segment of the joint, together with a portion of the bus body whose dimensions, to the extent permitted by the size of the joined parts, so that the specimen's centerline is perpendicular to the joint at the midpoint of the joint segment. Where the body panel joint is not fastened continuously, select the segment so that it does not bisect a spot weld or a discrete fastener.

If a joint is less than 203 mm long, cut a test specimen with enough of the adjacent material to permit it to be held in the tension testing machine specified in the guideline.

Prepare the test specimen in accordance with the preparation procedures specified in the 1973 edition of the Annual Book of ASTM Standards.

Determination of minimum allowable strength: For purposes of determining the tensile strengths of the joined body components as follows:

- Where the mechanical properties of a material are specified ASTM standards the relative tensile strength shall be equal to the minimum tensile strength specified in the corresponding ASTM Standards.
- Where the mechanical properties of a material are not specified in the ASTM standards, its tensile strength of representative sample from the bus body outside the area of the joint shall be taken for reference.

9. TYPE APPROVAL AND COP PROCEDURE

9.1 Scope

The Type Approval Procedure specified in this guideline is applicable to buses with a seating capacity of 14 passengers or above. The requirements also apply to the following vehicles except in respect of those provisions which are not compatible with the intended use and function of these vehicles:

- Buses all types
- Minibuses
- Special purpose buses: school buses, tourist service buses etc.

The system for approval of Prototype and Conformity to Production (COP) to comply with provisions with respect to the safety, strength and technical requirements specified in the Bus body building standards provided by the automobile manufactures or body building standards practiced in the country.

9.2 Procedure for Type Approval

The Type Approval shall be applicable to the following provisions for which compliance is sought by the vehicle manufacturer or Bus Body Builder as the case may be:

- Complete Vehicle Type Approval
- Bus Body Type Approval as a separate unit
- Vehicle Type Approval fitted with the Bus Body which is already type approved
- Prototype Type Approval of Vehicle and other aggregates / units

9.3 Application for Type Approval

The application for type approval shall be submitted to the test agency by the Vehicle Manufacturer / Bus Body Builder, with the description of the vehicle type (s) or body type (s) or the vehicle type fitted with an already approved body. This application shall be accompanied by the following documents, as applicable to the provisions for which compliance is sought.

- List of provisions for which compliance is sought /to be established.
- All the relevant information specified in the format “Information on Technical Specifications” to be submitted by Bus Body Builder given at last of this guidelines.
- Copies of certificates or test reports of compliance to various provisions, which may have already been obtained from other recognized Testing Agencies.
- Copies of test reports for other models/variants, if any, which can be used for establishing compliance of the model to be type approved, with a note explaining the details.
- Copy of certificate of incorporation of the manufacturer, if not already submitted.

In case of body builders, who have adopted any type tested designs provided by the chassis manufacturers, the body builder shall provide the necessary details and drawings of the chassis manufacturer, to the test agency for their consideration.

The specification of the bus body should have the approval of the registered Automobile or Mechanical engineer before it is submitted to the DoTM for the registration of modification of body. The overall process of type approval and process of registration is shown in Figure 10.

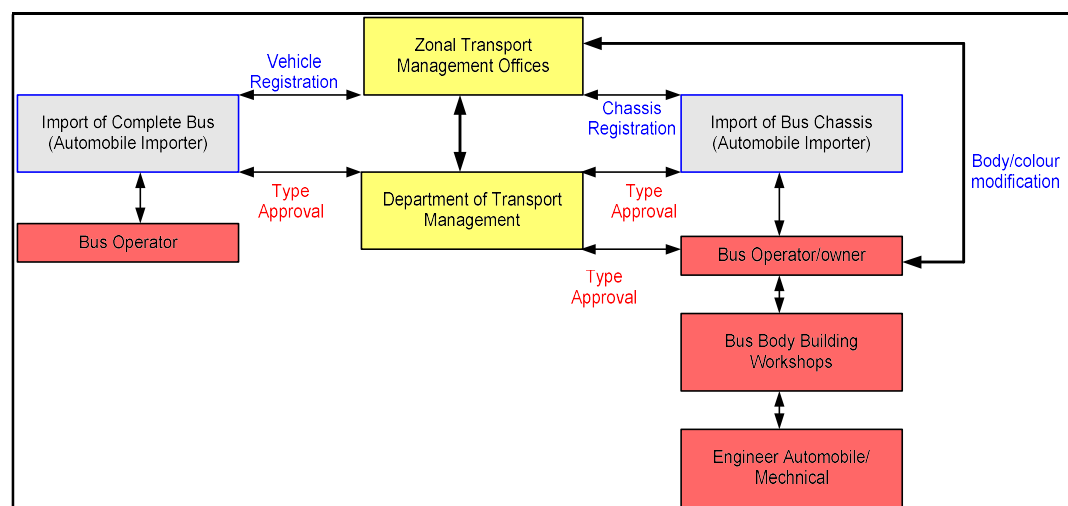

Figure 10 Body Fabrication and Type Approval

9.4 Type Approval of Safety Components / Sub-Assemblies

Type Approval of safety components including passenger seats and seat mountings, window sub-assembly, power operated service door, door components, luggage rack assembly etc. shall be obtained.

9.5 Methods of Establishing Compliance

Depending upon the provision, the compliance can be established by either comparison of the values declared in the Technical Specifications with those in the provisions of regulations, or checking the fitment of part(s) on the vehicle or by testing, as applicable.

9.6 Certificate of Compliance (Type-Approval)

After compliance is established for all the provisions, applicable to that model/variant(s), a Certificate of Compliance consolidating all applicable provisions shall be issued by the Testing Agency. The Brief Technical Specifications as declared by the manufacturer or body fabrication workshops shall be countersigned by the testing agency and shall be attached to the certificate of compliance.

10. TECHNICAL SPECIFICATION FORM

(To be submitted by the Vehicle Manufacturer / Body Builder to the Test Agency)

Table 15 Technical Specification Form

1.0	Details of Coach Builder
1.1	Builder's name & address :
1.2	Telephone No.
1.3	E mail address :
1.4	Contact person :
1.5	Name of model and variants :
1.6	Type and General commercial description (s) :
1.7	Plant/(s)of manufacture :

2.0	Vehicle Chassis Characteristics
2.1	Chassis types approved for Body installation:
2.2	Type of Control (normal control/Full forward control etc.)
2.3	Wheel base (s) :
2.4	Number of Axles and wheels :
2.5	Chassis (overall drawing) :
2.6	Frame Type :
2.7	Cross sectional view :
2.8	Dimensions: length and width :
2.9	Position and arrangement of engine :
2.10	Dimension (in mm) (Specify drawing reference) :
2.11	Length mm :
2.12	Width mm :
2.13	Height (Unladen) mm :
2.14	Wheel base mm :
2.15	Wheel track mm :
	Front :
	Rear :
2.16	Body overhang mm :

	Front end :
	Rear end :
2.17	Category of vehicle

3.0	Body
3.1	Type of Body: Type I, Type II, Type III. Type IV
3.2	Comfort Category SB, DLX, ACX
3.3	Dimension drawing and photograph of the vehicle with representative body Range of vehicle dimension (Overall):
3.4	Dimension drawing of the body depicting Chassis connecting members
3.5	Material used for construction:
3.5.1	Structural materials
3.5.2	Size of the section
3.6	Method of construction:
3.7	Area for passengers For Seated passengers For Standing passengers
3.8	Number of passengers Seated passengers Standing passengers
3.9	Passenger capacity including drivers
3.10	Number of Service doors :
3.11	Number of emergency exits :
3.12	Number of escape hatches :
3.13	Volume of luggage compartments(m3) :
3.15	Area of luggage Transportation on roof (m

4.0	Clearance
4.1	Minimum road clearance :
4.2	Road clearance from floor (for buses) :
5.0	Weights
5.1	Vehicle kerb weight kg :
	Front axle :
	Rear axle :
	Total :
5.2	Gross vehicle weight kg :
5.3	Maximum permissible axle weights kg Front axle Rear axle
5.4	Reference mass kg :
6.0	Max. stable inclination
	Left :
	Right:
7.0	Tyres
7.1	No, and arrangement of wheels Front: Rear Other:

7.2	Inflation pressure - Unladen :
	Front:
	Rear
	Other:
7.3	Inflation pressure - laden :
	Front:
	Rear
	Other:
8.0	Body Panels
8.1	Outer panels
	Materials
	Thickness
8.2	Inner panels
	Materials
	Thickness
8.3	Roof Panels
	Materials
	Thickness
8.4	Floor panels
	Materials
	Thickness
8.5	Type of anti-slip coating
9.0	Service doors
9.1	Number of service doors
9.2	Position of service doors
9.3	Dimension of service doors
9.4	Front
9.5	Rear
9.6	Middle

10.0	Emergency Exit
10.1	Number of Emergency doors
10.2	Position of emergency doors
10.3	Dimension of emergency doors
11.0	Emergency window
11.1	Number of Emergency doors
11.2	Position of emergency doors
11.3	Area of emergency window
12.0	Escape Hatch
12.1	Number of escape hatches
12.2	Position of escape hatches
13.0	Steps
13.1	Height of first step
13.2	Height of other steps
13.3	Depth of steps
13.4	Width:
13.5	Heights:
14.0	Floor
14.1	Floor Height from the ground
14.2	Slope of the floor

15.0 Gangway	Gangway
15.1	Height
15.2	Width (Diameter of gauging device-lower cylinder)
15.3	Width (diameter of gauging device-upper cylinder)
16.0	Hand Rails and Handholds
16.1	Position (attach dimension layout)
16.2	No. of handholds
16.3	Diameter of Handholds
16.4	Type of anti-slip coating/covering
17.0	Step-well guard
17.1	Height from the floor
17.2	Projection from the side wall
18.0	Passenger seats
18.1	Seat layout
18.2	Seat width
18.3	Width available for one seat
18.4	Height of backrest
18.5	Width of armrest
18.6	Depth of seat cushion (base)
18.7	Seat Spacing
18.8	Seat base height
18.9	Torso angle
18.10	Seat-base thickness
18.11	Seat back thickness
18.12	Clearance space for seated passengers facing partition
18.13	Free Height over seating position

19.0	Cabin Luggage Rack
19.1	Width from side wall :
19.2	Height from Roof
20.0	Driver Partition :
20.1	Dimension of partition with respect to rear edge of driver seat
21.0	Driver area
21.1	Width from the right side wall
21.2	Distance of driver partition from the driver seat back
21.3	Distance from H-point to Roof Top
21.4	Distance between Heel Point and H-Point
21.5	Distance of H-Point from Floor
21.6	Distance of lower end of steering wheel from driver seat back
21.7	Thigh clearance of Steering Wheel

22	Safety glass
22.1	Front wind shield (laminated)
22.1.1	Make and identification
22.1.2	Type (flat/curved, clear/tinted)
22.1.3	Thickness mm
22.1.4	No. of pieces
22.1.5	Radius of curvature (If curved) :
22.2	Side Windows :

22.2.1	Make and identification
22.2.2	Type(flat/curved, clear/tinted, toughened)
22.2.3	Thickness mm
22.2.4	Radius of curvature (If curved) :
22.3	Rear window
22.3.1	Make and identification
22.3.2	Type(flat/curved, clear/tinted, toughened)
22.3.3	Thickness mm :
22.3.4	Radius of curvature (If curved) :

23.0	Rear view mirror
23.1	Left :
23.1.1	Name of producer :
23.1.2	Type :
23.1.3	Dimension & radius of curvature
23.2	Right:
23.2.1	Name of producer
23.2.2	Type :
23.2.3	Dimension & radius of curvature :
23.3	Inside
23.3.1	Name of producer
23.3.2	Type
23.3.3	Dimension & radius of curvature

24.0	Wind Screen Wiper
24.1	Type :
24.2	No. of wipers
24.2.1	Name of manufacturer
24.2.2	Type and identification
24.2.3	Rated voltage
24.2.3	Frequency of wiping
24.2.0	Wiper arm
24.2.1	Length :
24.2.2	Manufacturer and Identification
24.3.0	Wiper blade
24.3.1	Length :
24.3.2	Manufacturer and Identification
24.3.3	Wind Screen Washer
24.3.4	Name of producer :
24.3.5	Number of nozzles :
24.3.6	Spray Area

25.0	Equipment for occupant's safety
25.1	Driver Seat belt
25.1.1	Name of producer
25.1.2	Type
25.1.3	Number
25.2.	Driver Seat belt anchorage
25.2.1	Name of producer :

25.2.2	Type :
25.2.3	Number :
25.3.0	Head restraint
25.3.1	Name of producer
25.3.2	Type :
25.4.0	Passenger Seat
25.4.1	Name of producer :
25.4.2	Type
25.4.3	Frame structure Material
25.4.4	Section size:
25.4.5	Pad material :
25.4.6	Upholstery

26.0	Bumper
26.1	Size: Front:
	Rear:
26.2	Projection
27.3	Clearance between bumper & body
33.0	Fuel filler
33.1	Aperture
33.2	Position
34.0	Fire Extinguisher
34.1	Number
34.2	Type
34.3	Capacity
34.4	Name of Producer
35.0	First Aid Equipment
35.1	Number
35.2	Contents
36.0	Towing devices
36.1	Type
36.2	Name of manufacturer
36.3	Capacity
37.0	Number Plate lamp
37.1	Name of producer
37.2	Type and Identification
37.3	Number and colour
38.0	Tail lamp
38.1	Name of producer
38.2	Type and Identification
38.3	Number and colour :
39.0	Parking lamp
39.1	Front
39.1.1	Name of producer
39.1.2	Type and identification
39.1.3	Number and colour
39.2	Rear
39.2.1	Name of producer
39.2.2	Type and identification
39.2.3	Number and colour

40.0	Stop Lamp
40.1	Name of producer
40.2	Type and identification
40.3	Number and colour
41.0	Reversing Lamp
41.1	Name of producer
41.2	Type and identification
41.3	Number and colour
42.0	Direction indicator
42.1	Front
42.1.1	Name of producer
42.1.2	Type and identification
42.1.3	Number and colour
42.2	Rear
42.2.1	Name of producer
42.2.2	Type and identification
42.2.3	Number and colour
42.3	Side
42.3.1	Name of producer
42.3.2	Type and identification
42.3.3	Number and colour

43.0	Emergency signaling equipment
43.1	Front
43.1.1	Name of producer
43.1.2	Type and identification
43.1.3	Number and colour
43.2	Rear
43.2.1	Name of producer
43.2.2	Type and identification
43.2.3	Number and colour
43.3	side
43.3.1	Name of producer
43.3.2	Type and identification
43.3.3	Number and colour
44.0	Reflector
44.1	Front
44.1.1	Name of producer
44.1.2	Type and identification
44.1.3	Number and colour
44.1.4	Area
44.2	Rear
44.2.1	Name of producer
44.2.2	Type and identification
44.2.3	Number and colour
44.2.4	Area
44.3	Side :
44.3.1	Name of producer :
44.3.2	Type and Identification :

44.3.3	Number and colour :
44.3.4	Area :

45.0	Top light
45.1	Name of producer :
45.2	Type and Identification :
45.3	Number and colour :
46.0	Internal Lighting & Illumination
46.1	Driver Cab lighting :
46.1.1	Type :
46.1.2	Name of producer :
46.1.3	Number :
46.1.4	illumination intensity :
46.2	Passenger Compartment Lighting
46.2.1	Type :
46.2.2	Name of producer :
46.2.3	Number :
46.2.4	Illumination intensity :
46.3	Other Area Lighting
46.3.1	Type :
46.3.2	Name of producer :
46.3.3	Number :
46.3.4	Illumination intensity :
47.0	Electrical Circuit
47.1	Circuit Diagram (attach details):
48.0	Electrical Cables
46.3.1	Type :
46.3.2	Name of producer :
46.3.3	Number :
46.3.4	Illumination intensity :
47.0	Electrical Circuit
47.1	Circuit Diagram (attach details):

48.0	Electrical Cables
48.1	Name of producer :
48.2	Conductor Cross section :
48.3	Insulation Class :
49.0	Fuse
49.1	Type & Make :
49.2	Name of producer :
49.0	Master switch for electrical :
50.1	Type & Make :
50.2	Name of producer:
50.2	Name of producer: